

6HP21

6-Gang-Automatgetriebe für Pkw
6 speed automatic transmission for cars

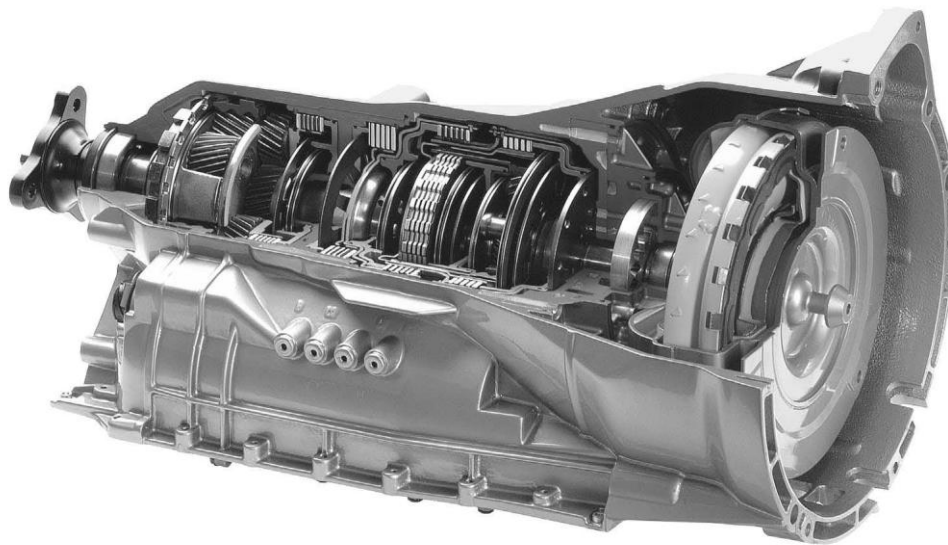

Getriebetyp / Transmission type		6HP21			
Antriebsart Type of drive		Standard / Standard drive			
Eingangsdrehmoment Input torque		max. 230 Nm	max. 320 Nm	max. 400 Nm	max. 440 Nm
Drehmomentwandler Torque converter		W230SR- 2GWK TTD	W240SR- 2GWK TTD	ZDW240- 2GWK	W255RH- 4GWK TTD
Standard-Übersetzungen / Standard ratios Gang / Gear				4.17	
				2.34	
				1.52	
				1.14	
				0.87	
				0.69	
				3.40	
Getriebespreizung Transmissions spreading		6.04			
Masse ohne Anbauteile (incl. Öl) Weight without ancillaries (incl. oil)		73.5 kg	74.5 kg	79.5 kg	78 kg
Ölmenge Oil capacity		≈ 8.5 dm ³			
Getriebeöl Transmission oil		Lebensdauerölfüllung Lifetime oil fill			

6HP21

Einbaumaße / Installation dimensions

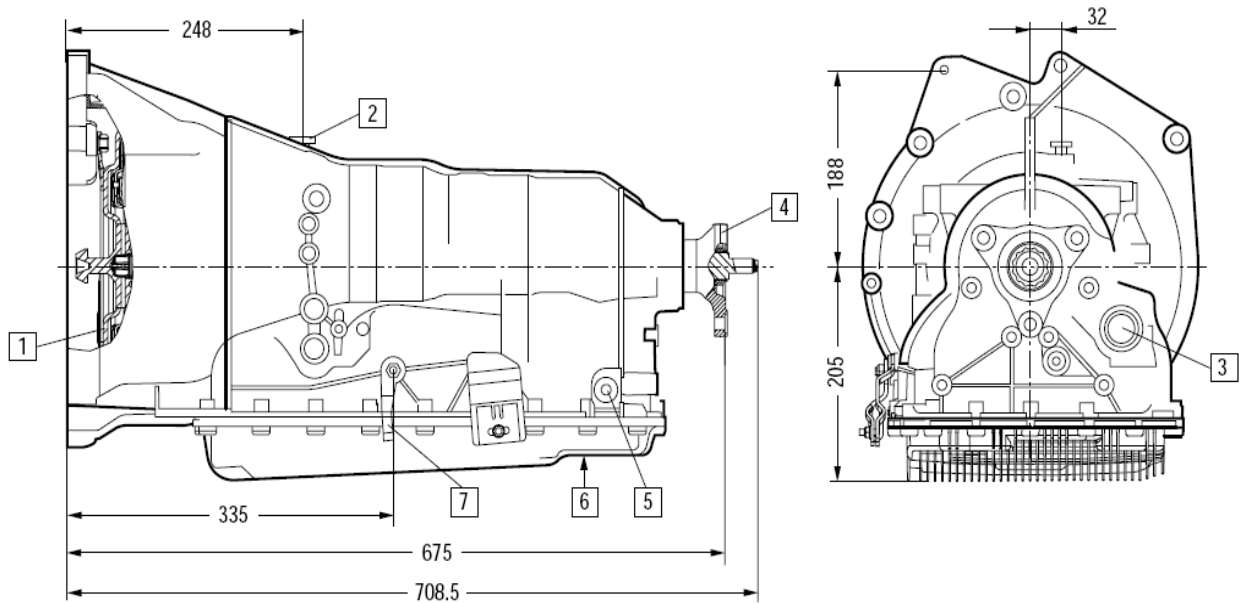

- | | | | |
|---|---|---|--|
| 1 | Wandler / Torque converter | 5 | Öleinfüllung und Ölüberlaufmessung /
Oil fill and oil overflow |
| 2 | Entlüfter / Breather | 6 | Ölablass / Oil drain |
| 3 | Steckeranschluss zum Fahrzeugsystem /
Plug connection to vehicle systems | 7 | Notentriegelung Parksperre (Shift-by-wire) oder
Wählhebel (manuell)
Emergency disengagement of parking brake
(Shift-by-wire) or selector lever (manually) |
| 4 | Abtrieb / Output | | |

Highlights

- **Standabkopplung / Neutral idle control**
- **Mechatronik (integrierte Getriebesteuerung) / Mechatronic (integrated transmission control)**
- **ASIS - adaptive Schaltstrategie / ASIS - adaptive shifting strategy**
- **Hohe Leistung bei geringem Gewicht (auf Basis des Lepelletier-Radsatzkonzeptes) / High power-to-weight ratio (based on lepelletier gear set concept)**